



GAI-TRONICS® CORPORATION
A HUBBELL COMPANY

Model XSA2000A Conversion Kit ITA2000A to ITA2000S

Field Installation Kit Instructions

Confidentiality Notice

This manual is provided solely as an operational, installation, and maintenance guide and contains sensitive business and technical information that is confidential and proprietary to GAI-Tronics. GAI-Tronics retains all intellectual property and other rights in or to the information contained herein, and such information may only be used in connection with the operation of your GAI-Tronics product or system. This manual may not be disclosed in any form, in whole or in part, directly or indirectly, to any third party.

General Information

The Model XSA2000A Conversion Kit provides the equipment necessary to convert a standard Model ITA2000A Tone Remote Adapter to a Model ITA2000S **Scanning** Tone Remote Adapter. This kit includes the following components:

Qty	Description
1	EPROM, 50086-079
1	Label, 25326-094
1	Pub. 43004-018A, ITA2000S Installation and Service Manual

Installation



Warning: Observe precautions for handling electrostatic sensitive devices.

Proper grounding is advised.

1. Remove the 4 screws holding the cover of the Model ITA2000A in place. Remove the cover.
2. Extract the EPROM (U2) from the PCBA. See Figure 1 for the location.

3. Replace it with the EPROM provided in this kit taking care to observe the direction indicated on the socket and the EPROM. Ensure the pins are seated and not bent. Make sure the connectors fit properly into the cover.
4. Replace the cover and secure it with the four screws.
5. Carefully apply the label supplied with this kit onto the front of the tone adapter in the position shown in Figure 1.

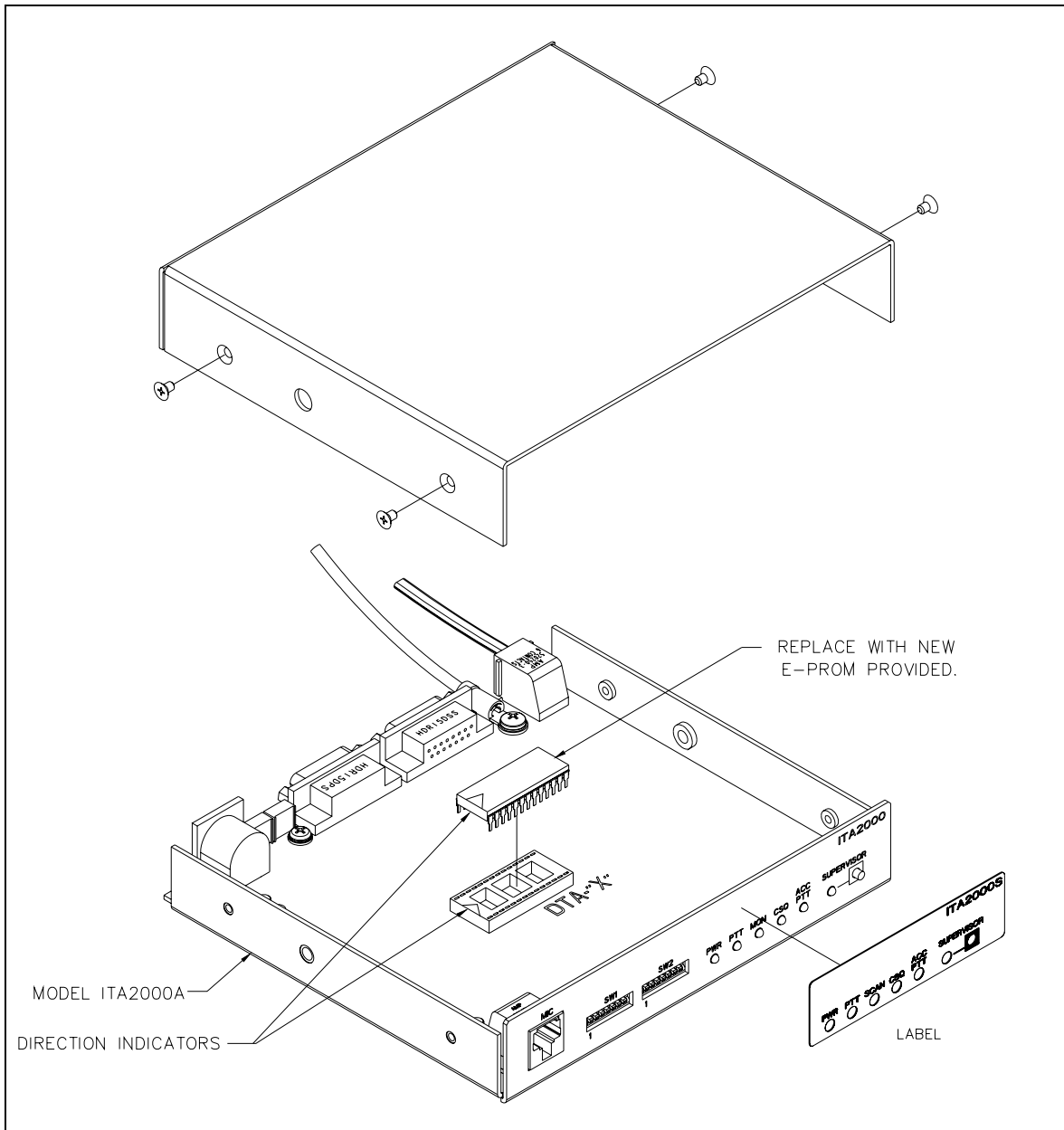

Figure 1.